

Pond Filter Pumps

UP-800-F
UP-970-F
UP-1150-F

Submersible Pumps for Decorative Fountains, Waterfalls and Aquariums

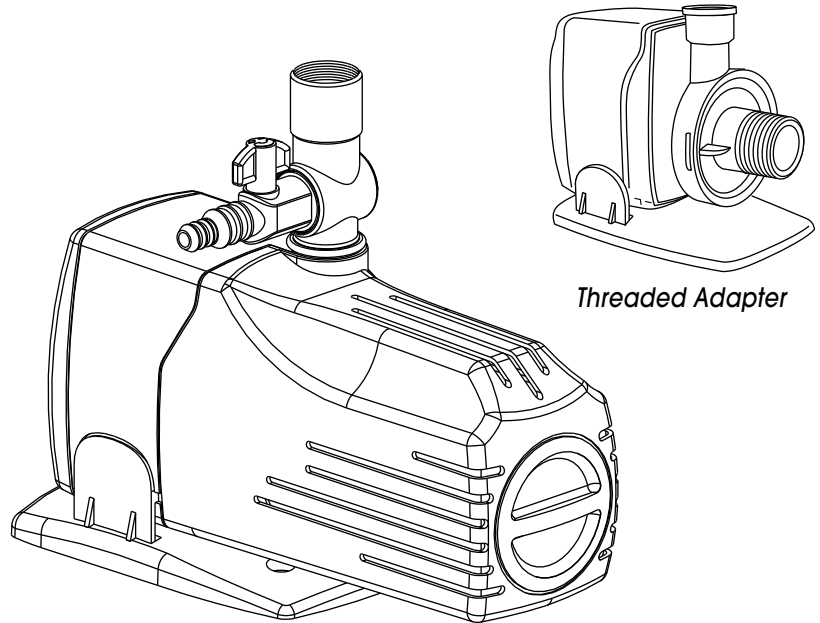

Accessories sold separately.
 See available fountain accessories on pages 16 and 17.

Pump Performance Chart

Stock No.	Watts	Max Head	GPH	6"	1'	2'	3'	4'	5'	6'	7'	8'	9'	L	W	H
UP-800-F	57	112"	793	770	750	700	650	580	500	420	300	175	50	10-1/2"	4-5/8"	5-7/8"
UP-970-F	73	110"	978	950	925	870	790	680	630	475	342	130	0	10-1/2"	4-3/4"	5-7/8"
UP-1150-F	93	151"	1150	1111	1087	1023	929	799	740	558	402	200	0	10-1/2"	4-3/4"	5-7/8"

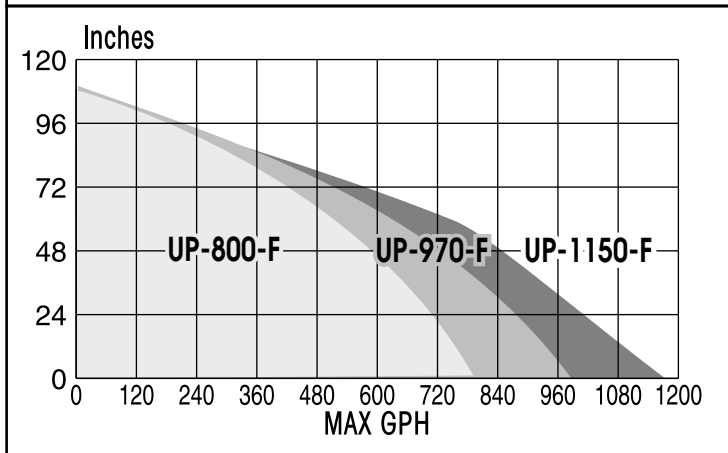

- Energy saving, low operating cost.
- Ceramic-coated 316 stainless steel shaft for ultimate durability.
- Complies to all international and domestic safety standards (UL listed).
- Outlet 3/4" female threaded.
- 1" MIP inline adapter on each model.

United Pump's pumps are efficient and reliable. These pumps may be disassembled without the use of tools for easy cleaning.

United Pump, Inc.
 2357 Ventura Dr., Suite 102
 Woodbury, MN 55125

Phone: 651-731-1001
 Fax: 651-731-8404

