

UP-500-F
 UP-630-F
 UP-700-F
 UP-900-F

Pond Filter Pumps

Submersible Pumps for Decorative Fountains, Waterfalls and Aquariums

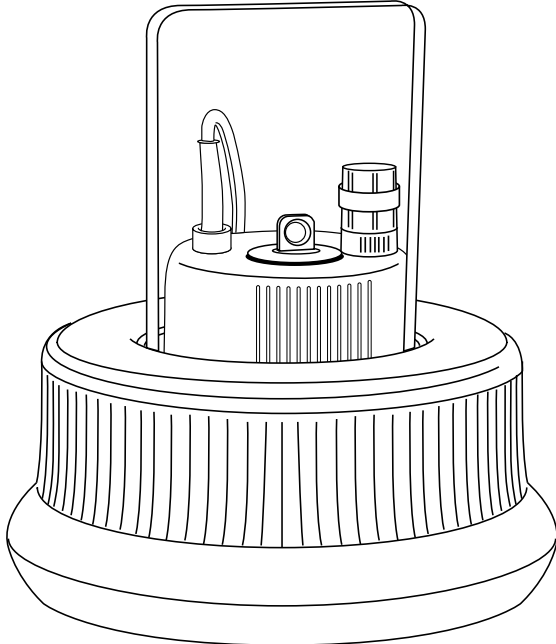

*Accessories sold separately.
 See available fountain accessories on pages 16 and 17.*

Pump Performance Chart

Stock No.	Watts	Max Head	GPH	6"	1'	2'	3'	4'	5'	6'	7'	8'	9'	L	W	H
UP-500-F	27	68"	502	460	440	370	250	160	60	0	0	0	0	9-3/4"	9-3/4"	6-1/8"
UP-630-F	41	90"	634	570	550	490	400	330	250	175	75	0	0	9-3/4"	9-3/4"	6-1/8"
UP-700-F	65	104"	713	690	650	590	480	370	330	225	180	15	0	9-3/4"	9-3/4"	6-7/8"
UP-900-F	74	110"	925	910	900	850	760	690	600	510	450	180	100	9-3/4"	9-3/4"	6-7/8"

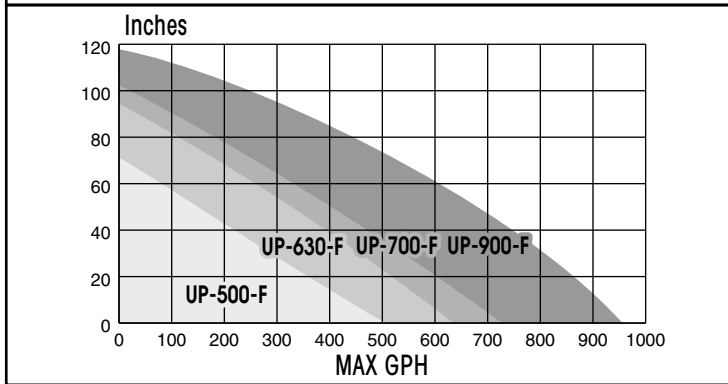

- Energy saving, low operating cost, mag driven rotor.
- Complies to all international and domestic safety standards (UL listed).
- Ceramic-coated 316 stainless steel shaft for ultimate durability.
- Outlet 1/2" male threaded.
- 1/2" female coupling provided.
- Removable filter cage.

**UNITED
 PUMP** INC.



United Pump, Inc.
 2357 Ventura Dr., Suite 102
 Woodbury, MN 55125

Phone: 651-731-1001
 Fax: 651-731-8404

United Pump's pumps are efficient and reliable. These pumps may be disassembled without the use of tools for easy cleaning.