

Pond Filter Pumps

Submersible Pumps for Decorative Fountains, Waterfalls and Aquariums

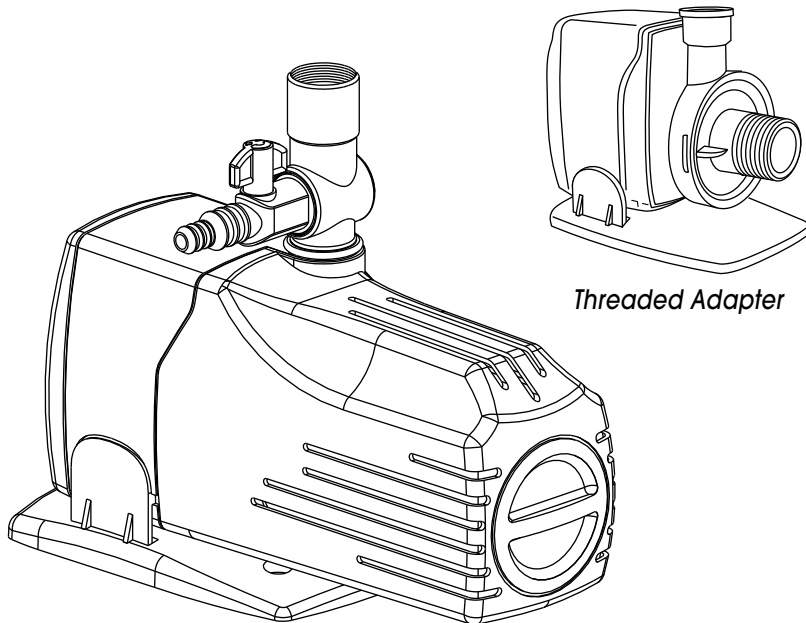

Fountain Accessories Sold Separately



Threaded Adapter

Pump Performance Chart

Stock No.	Watts	Max Head	GPH	6"	1'	2'	3'	4'	5'	6'	7'	8'	L	W	H
UP-1150-F	93	151"	1150	1111	1087	1023	929	799	740	558	402	200	10-1/2"	4-3/4"	5-7/8"

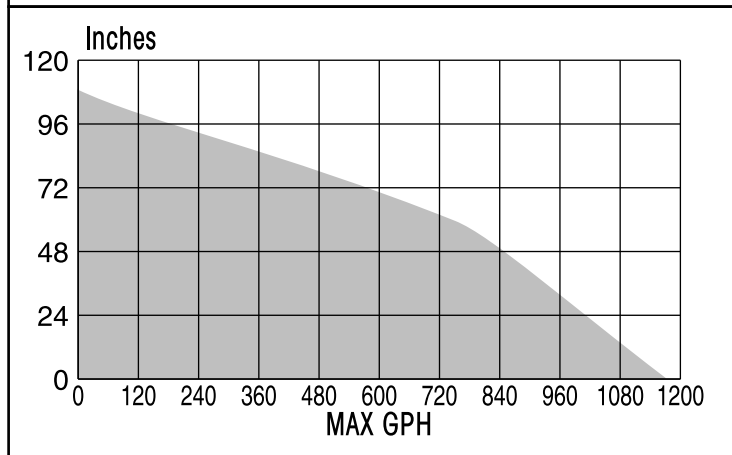

- Energy saving, low operating cost.
- Ceramic-coated 316 Stainless Steel shaft for ultimate durability.
- Made of space-age materials and non-corrosive.
- Complies to all international and domestic safety standards (UL listed).
- UP-1150-F come with barbed adapter for 3/4" ID tubing.
- Outlet 3/4" female threaded.
- 1" MIP inline adapter on each model.

United Pump's pumps are reliable, efficient and attractive. All pumps may be disassembled without the use of tools for easy cleaning.

United Pump, Inc.
2357 Ventura Dr., Suite 102
Woodbury, MN 55125

Phone: 651-731-1001
Fax: 651-731-8404

