

# Mini Table Top Fountain Pump

Submersible Pumps for Decorative Fountains, Waterfalls and Aquariums

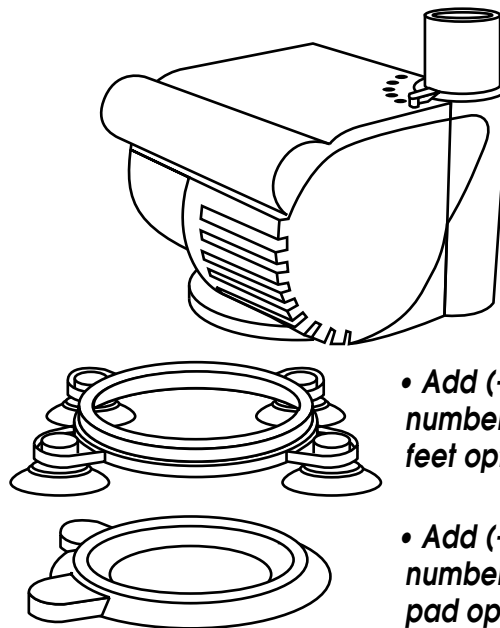

• Add (-SF) to model number for suction feet option.

• Add (-OB) to model number for O-Base pad option.

## Pump Performance Chart

Stock No.	Watts	Max Head	GPH	6"	12"	18"	24"	30"	36"	42"	48"	L	W	H
UP/AP-75	6	24"	70	60	45	20	0	0	0	0	0	2-1/8"	2"	1-1/2"

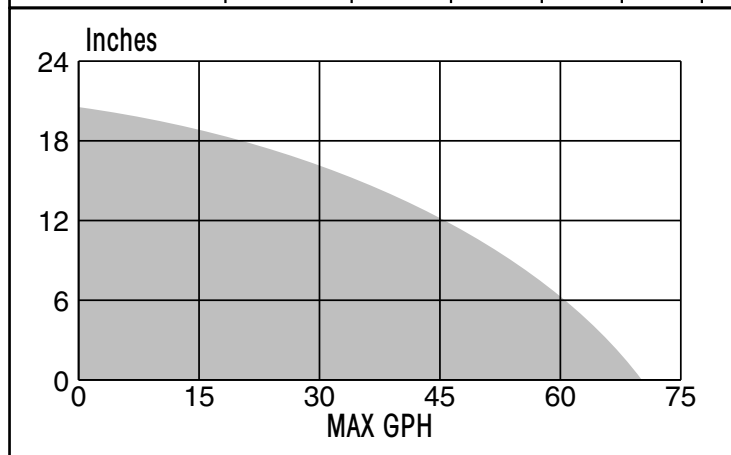

- The perfect tiny pump for the smallest table-top fountains and hobby projects.
- Energy saving, low operating cost mag driven rotor.
- Available in 2-wire for indoors and 3-wire for outdoor use.
- Fully adjustable flow from 0 - 70 GPH.
- Add (-S) for optional ON/OFF switch.
- Standard 1/2" OD outlet.
- UP-75 complies to all international and domestic safety standards (CSA, NRTL-C, UP-75 UL listed).

*United Pump's pumps are efficient and reliable. These pumps may be disassembled without the use of tools for easy cleaning.*

United Pump, Inc.  
2357 Ventura Dr., Suite 102  
Woodbury, MN 55125

Phone: 651-731-1001  
Fax: 651-731-8404

